

Recommended Barriers

Recommended Barriers for Use with Burkert's Intrinsically Safe Solenoid Valves

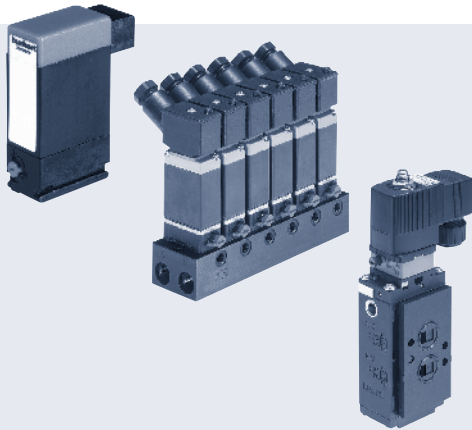

Picture showing 3 examples of intrinsically safe valve systems

- EXi solenoid valve solutions
- PTB EEx ia IIC T5 and T6 approved for Europe
- FM IS / I, II, III / ABCDEFG approved for USA

Burkert offers a wide range of intrinsically safe solutions for use in hazardous areas. For the power supply of these products an approved barrier is required. This data sheet gives you an overview of approved solutions.

Applications

- Chemical industry
- Pharmaceutical processing equipment
- Industrial waste water treatment
- Oil and gas industry

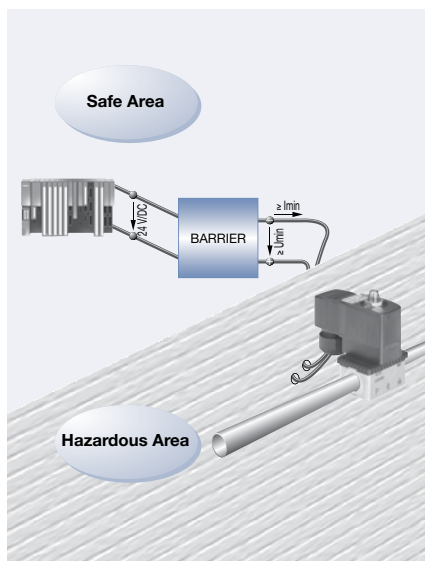

Recommended Barriers

List of approved barriers

Following barriers are tested for use with our EExi valves in Zone 1

| Supplier | Type | Max. Resistance at 55°C |
|------------------------|--------------------------------|-------------------------|
| Bartec | Modex 07-7311-93M6/P060 | 144 Ω |
| | 19-100.2801/1010 | 163 Ω |
| CEAG | SB-0728 | 100 Ω |
| | SB-1728 | 100 Ω |
| | 6/915-7 | 70 Ω |
| | 7/915-7 | 70 Ω |
| | 2/915-7 | 70 Ω |
| | 4/915-7 | 70 Ω |
| | 5/915-7 | 70 Ω |
| | LB 2112 | 154 Ω |
| | FB 2112 | 154 Ω |
| Hima | F3328 (Characteristics A or C) | 140 Ω |
| H & B | V17132-55 | 273 Ω |
| | V17332-61 | 200 Ω |
| MTL | 728 | 140 Ω |
| | 4021 | 154 Ω |
| | 4728 | 110 Ω |
| | 7028+ | 108 Ω |
| | 7028- | 108 Ω |
| | 4025 | 93 Ω |
| | 5025 | 68 Ω |
| | 8215-DO-IS | 195 Ω |
| | P & F | KFD2-SD-Ex1.48 |
| KFD2-SL-Ex1.48 | | 97 Ω |
| KFD2-SD-Ex1.48.90A | | 97 Ω |
| KFD2-SL-Ex1.48.90A | | 97 Ω |
| Z 728 | | 140 Ω |
| Z 828 | | 140 Ω |
| Z 728.CL | | 140 Ω |
| Z 828.CL | | 140 Ω |
| KSD2-BO-Ex | | 173 Ω |
| RSD-BO-Ex4 | | 106 Ω |
| VAA-2EA-G5-N/V1-Ex | | 203 Ω |
| EGA-041-3 | | 120 Ω |
| ED2-VD-Ex.2.1835 | | 160 Ω |
| Phoenix Contact | PI/Ex-SD/22/45-C | 191 Ω |
| Steel | 9351/10-16-10 | 163 Ω |
| | 9151/10-16-10 | 193 Ω |
| | 9475/12-04-21 | 144 Ω |
| | 9475/12-04-31 | 82 Ω |
| | 9475/12-08-51 | 54 Ω |
| | 9651/40-16-10 | 233 Ω |
| | 9001/01-280-100-10 | 138 Ω |
| | 9001/01-252-100-14 | 182 Ω |
| Turck | MC 72-41Ex-T | 157 Ω |
| | MC 72-43Ex-T | 157 Ω |

Please contact your Burkert representative if your preferred barrier is not on this list.

Technical data – coil AC10 EExi

Approved to:
PTB EEx ia IIC T6, T5
FM IS / I, II, III / ABCDEFG

Coil used in following

Burkert valves:

- 0590 EExi
- 0590 NAMUR EExi
- 6013 EExi
- 6014 EExi
- 6518 EExi
- 6519 EExi
- 6519 NAMUR EExi

| Values for switching function | at 68°F | at 131°F |
|---|--------------|--------------|
| Min. switching current (≥ 14.5 PSI) | 29 mA | 29 mA |
| Nominal resistance coil | 310 Ω | 360 Ω |
| Minimum terminal voltage | 9.0 V | 10.4 V |

**Example of max. allowable combinations
acc. to certificate of conformity**

| | |
|----------------|---|
| U _i | 28 V |
| I _i | 120 mA |
| P _i | 1.1 W |
| T amb max. | 140°F ^(T6) 167°F ^(T5) |

Technical data – coil AC21 EExi

Approved to:
PTB EEx ia IIC T6, T5
FM IS / I, II, III / ABCDEFG

Coil used in following

Burkert valves:

- 0450 EExi
- 5470 M EExi
- 5470 NAMUR EExi
- 6106 EExi
- 6516 EExi
- 6517 EExi
- 8640 EExi*

(*if used with 0450 EExi and 5470 M EExi)

| Values for switching function | at 68°F | at 131°F |
|---|--------------|--------------|
| Min. switching current (≥ 14.5 PSI) | 29 mA | 29 mA |
| Nominal resistance coil | 320 Ω | 360 Ω |
| Minimum terminal voltage | 9.3 V | 10.4 V |

**Example of max. allowable combinations
acc. to certificate of conformity**

| | |
|---|-------------------------------|
| U _i | 28 V |
| I _i | 120 mA |
| P _i /T amb max (block assembly) | 0.7 W / 122°F ^(T6) |
| P _i /T amb max (block assembly) | 0.9 W / 140°F ^(T5) |
| P _i /T amb max (single mounting) | 0.9 W / 131°F ^(T6) |
| P _i /T amb max (single mounting) | 0.9 W / 158°F ^(T5) |

Technical data – coil AC6104 EExi

Approved to:
PTB EEx ia IIC T6, T5
FM IS / I, II, III / ABCDEFG

Coil used in following

Burkert valves:

- 6104 EExi
- 6510 EExi
- 6511 EExi

| Values for switching function | at 68°F | at 131°F |
|---|--------------|--------------|
| Min. switching current (≥ 14.5 PSI) | 29 mA | 29 mA |
| Nominal resistance coil | 320 Ω | 360 Ω |
| Minimum terminal voltage | 9.3 V | 10.4 V |

**Example of max. allowable combinations
acc. to certificate of conformity**

| | |
|---|-------------------------------|
| U _i | 28 V |
| I _i | 120 mA |
| P _i /T amb max (block assembly) | 0.5 W / 104°F ^(T6) |
| P _i /T amb max (block assembly) | 0.6 W / 122°F ^(T5) |
| P _i /T amb max (single mounting) | 0.5 W / 122°F ^(T6) |
| P _i /T amb max (single mounting) | 0.7 W / 140°F ^(T5) |

Recommended Barriers
